



Non-Asbestos Industrial Friction Materials



GEARTOOTH & INDUSTRIAL FACINGS

Manufactured by:
SCAN-PAC MFG., INC.

N84 W13510 Leon Rd. • Menomonee Falls, WI 53051
Phone: 262.255.2525 • Fax: 262.255.2528
Email: sales@scanpac.com • website: www.scanpac.com

**GEARTOOTH &
INDUSTRIAL FACINGS**

RF 38 GEAR TOOTH FACINGS

SPM#	MAT'L	THK.	I.D.	O.D.	NO. TEETH	NO. SEGS	CLUTCH SIZE	MFG.	MFG./P/N
GT67501	RF38	0.438	2.38	6.75	15	1	5	RUELAND	97006-2105
GT72501	RF38	0.438	3.63	7.25	42	1	6	TWIN DISC	A3507
GT72502	RF38	0.375	3.63	7.25	42	1	6	TWIN DISC	A3507A
GT72503	RF38	0.438	3.63	7.25	42	3	6	TWIN DISC	A3507S
GT72504	RF38	0.438	4.75	7.25	42	3	6	TWIN DISC	4596S
GT72506	RF52	0.438	4.19	7.23	42	1	6	WICHITA	397-11-1
GT72507	RF52	0.438	4.00	7.25	42	1	6	TWIN DISC	A3507D
GT72508	RF52	0.375	4.38	7.25	42	1	6	TWIN DISC	
GT72505	RF38	0.375	4.00	7.25	42	3	6.5	ROCKFORD	CL8645
GT80801	RF38	0.438	4.50	8.08	47	1	7	TWIN DISC	A5436
GT80802	RF38	0.438	4.50	8.08	47	2	7	TWIN DISC	A5436A
GT80803	RF38	0.438	4.50	8.08	47	3	7	TWIN DISC	A5436S
GT72509	RF38	0.250	3.72	7.25	24	1	7.25	STEARNS	8-004-707-00
GT80804	RF38	0.438	4.50	8.08	47	3	7.5	ROCKFORD	CL8786
GT87501	RF38	0.438	5.50	8.75	51	1	8	TWIN DISC	6479
GT87502	RF38	0.438	5.50	8.75	51	2	8	TWIN DISC	6479C
GT87503	RF38	0.438	5.50	8.75	51	3	8	TWIN DISC	6479S
GT87504	RF38	0.375	5.50	8.75	51	3	8	ROCKFORD	CL7039
GT87505	RF34	0.438	5.40	8.70	51	1	8	ROCKFORD	
GT87505	RF52	0.438	5.40	8.70	51	1	8	WICHITA	275-25
GT87506	RF52	0.438	3.75	8.70	51	1	8	WICHITA	
GT87508	RF38	0.438	5.50	8.75	51	1	8	WICHITA	
GT92201	RF38	0.250	3.72	9.25	24	1	9		
GT10701	RF38	0.438	5.50	10.75	63	1	10	TWIN DISC	5878
GT10702	RF38	0.438	5.50	10.75	63	2	10	TWIN DISC	5878D
GT10703	RF38	0.438	5.50	10.75	63	3	10	TWIN DISC	5878S
GT10705	RF38	0.203	7.44	10.75	63	1	10	TWIN DISC	5904
GT10706	RF38	0.203	7.44	10.75	63	2	10	TWIN DISC	5904S
GT10707	RF38	0.438	6.25	10.75	63	3	10	ROCKFORD	CL6952
GT10708	RF38	0.438	6.50	10.75	63	1	10	TWIN DISC	5878B
GT10709	RF38	0.438	6.50	10.75	63	3	10	TWIN DISC	5878B
GT10710	RF38	0.438	3.75	10.75	63	1	10	TWIN DISC	5878M
GT10710	RF52	0.438	3.75	10.75	63	1	10	TWIN DISC	5878M
GT10711	RF38	0.375	5.31	10.00	55	1	10	STEARNS	8-004-206-00
GT10713	RF38	0.438	6.25	10.75	63	1	10	STEARNS	
GT12201	RF38	0.438	6.25	12.25	72	1	11	TWIN DISC	A5579
GT12202	RF38	0.438	6.25	12.25	72	2	11	TWIN DISC	A5579C
GT12203	RF38	0.438	6.25	12.25	72	3	11	TWIN DISC	A5579A
GT12204	RF38	0.250	6.25	12.25	72	1	11	TWIN DISC	A5579G
GT12205	RF38	0.438	8.00	12.25	72	1	11	TWIN DISC	6614
GT12206	RF38	0.438	8.00	12.25	72	2	11	TWIN DISC	6614D
GT12207	RF38	0.438	8.00	12.25	72	3	11	TWIN DISC	6614A
GT12208	RF38	0.438	6.25	12.25	72	3	11.5	ROCKFORD	CL10145
GT12209	RF38	0.438	6.25	12.25	72	4	11.5	ROCKFORD	CL10321
GT12210	RF52	0.500	7.00	12.22	72	1	11	WICHITA	265-4

RF 38 GEAR TOOTH FACINGS

SPM#	MAT'L	THK.	I.D.	O.D.	NO. TEETH	NO. SEGS	CLUTCH SIZE	MFG.	MFG./P/N
GT12211	RF52	0.500	4.25	12.25	72	1	11		
GT14204	RF41	0.250	9.25	14.94	44	1	14	UNIT CRANE	202397A-3
GT14801	RF38	0.625	9.25	14.88	44	1	14	UNIT CRANE	201821
GT14802	RF38	0.625	9.25	14.94	88	1	14	UNIT CRANE	22702A
GT14803	RF38	0.625	9.25	14.88	88	1	14	TWIN DISC	5740
GT14803	RF52	0.625	9.25	14.88	88	1	14	TWIN DISC	5740
GT14804	RF52	0.625	9.50	14.88	88	1	14	WICHITA	4-253-897-000
GT14805	RF38	0.438	9.25	14.88	44	1	14	WICHITA	
GT15101	RF38	0.625	9.25	15.13	59	1	14	TWIN DISC	5659M
GT15102	RF38	0.625	9.75	15.13	59	3	14	TWIN DISC	5659A
GT15103	RF38	0.625	9.25	15.13	59	3	14	TWIN DISC	5659B,J
GT15104	RF38	0.625	9.75	15.13	59	1	14	TWIN DISC	5659C,P
GT15104	RF52	0.625	9.75	15.13	59	1	14	TWIN DISC	5659C,P
GT15105	RF38	0.625	7.00	15.13	59	1	14	TWIN DISC	5659K
GT15106	RF38	0.625	7.00	15.13	59	3	14	TWIN DISC	5659L
GT15107	RF38	0.625	8.38	15.13	59	1	14	ROCKFORD	CL6954
GT15108	RF38	0.625	8.38	15.13	59	3	14	ROCKFORD	CL9927
GT15109	RF52	0.625	9.50	15.13	59	1	14	WICHITA	253-25-2
GT15110	RF38	0.625	9.25	15.13	59	1	14	TWIN DISC	5659D
GT15110	RF52	0.625	9.25	15.13	59	1	14	TWIN DISC	5659D
GT15112	RF52	0.500	9.75	15.13	59	1	14	TWIN DISC	
GT16101	RF38	0.625	9.25	17.16	67	3	16	TWIN DISC	6961C
GT16102	RF38	0.625	9.25	17.16	67	1	16	TWIN DISC	6961A,B
GT16103	RF38	0.625	10.00	17.16	67	1	16	TWIN DISC	6961D
GT16104	RF52	0.625	10.53	17.12	67	1	16	WICHITA	404-25
GT19101	RF38	0.625	12.50	19.13	75	1	18	TWIN DISC	5658
GT19102	RF38	0.625	12.50	19.13	75	2	18	TWIN DISC	5658A
GT19103	RF38	0.625	12.50	19.13	75	3	18	TWIN DISC	5658C
GT19104	RF52	0.625	12.56	19.13	75	1	18	WICHITA	234-25-1
GT19107	RF52	1.005	12.56	19.13	75	1	18	WICHITA	
GT22101	RF38	0.688	12.50	22.16	87	1	21	TWIN DISC	6971A
GT22102	RF38	0.688	12.50	22.16	87	3	21	TWIN DISC	6971B,S
GT22103	RF52	0.750	14.56	22.13	87	1	21	WICHITA	254-10-1
GT25101	RF38	0.875	14.50	25.16	99	1	24	TWIN DISC	5667A
GT25103	RF38	0.875	14.50	25.16	99	3	24	TWIN DISC	5667B
GT25104	RF38	0.875	17.50	25.16	99	1	24	TWIN DISC	5667C
GT25105	RF52	0.875	14.56	25.07	99	1	24	WICHITA	230-25
GT25106	RF52	0.875	17.50	25.07	99	1	24	WICHITA	230-25-8
GT28101	RF52	0.875	16.25	28.10	111	1	27	WICHITA	4-296-007-000-0
GT31101	RF38	0.875	21.00	31.16	123	1	30	TWIN DISC	8461C
GT31102	RF38	1.250	21.00	31.16	123	1	30	TWIN DISC	8461A
GT31103	RF38	1.250	21.00	31.16	123	3	30	TWIN DISC	8461B
GT31104	RF52	1.250	19.50	31.03	123	1	30	WICHITA	4-231-007-039
GT37101	RF38	1.250	24.00	37.16	147	1	36		
GT37101	RF52	1.250	24.00	37.16	147	1	36		

RF 34 (Non-Asbestos) - CLUTCH SEGMENTS

SP #		O.E.M. #	BLOCKS REQUIRED/ SET
CS1155	L or R	11.5VC500	8
CS1450	L or R	14VC500	8
CS1660	L or R	16VC600	8
CS2060	L or R	20VC600	10
CS2465	L or R	24VC650	12
CS2865	L or R	28VC650	14
CS3365	L or R	33VC650	16
CS3565	L or R	35VC650	18
CS3765	L or R	37VC650	18
CS4265	L or R	42VC650	20
CS1210	L or R	12VC1000	16
CS1410	L or R	14VC1000	16
CS1610	L or R	16VC1000	8
CS2010	L or R	20VC1000	8
CS2410	L or R	24VC1000	10
CS2810	L or R	28VC1000	10
CS3210	L or S	32VC1000	12
CS3812	L or S	38VC1200	12
CS4212	L or S	42VC1200	14
CS4612	L or S	46VC1200	16
CS5212	L or S	52VC1200	36
CS5116	L or S	51VC1600	36
CS6016	L or S	60VC1600	40
CS6616	L or S	66VC1600	44

NOTE 1: L suffix is for lining only sets
R or S suffix is for lining sets with rivets or screws

NOTE 2: If used with copper or bronze water cooled drum use RF 42 material

RF 34 (Non-Asbestos) - CLUTCH SEGMENTS

SP #	O.E.M. #	BLOCKS REQUIRED/ SET
CS1647	16E475	14
CS1947	19VE475	12
CS2147	21VE475	14
CS2447	24VE475	16
CS2747	27VE475	16

NOTE 1: L suffix is for lining only sets
R or S suffix is for lining sets with rivets or screws

NOTE 2: If used with copper or bronze water cooled drum use RF 42 material

RF 38 SQUARE ID FACINGS

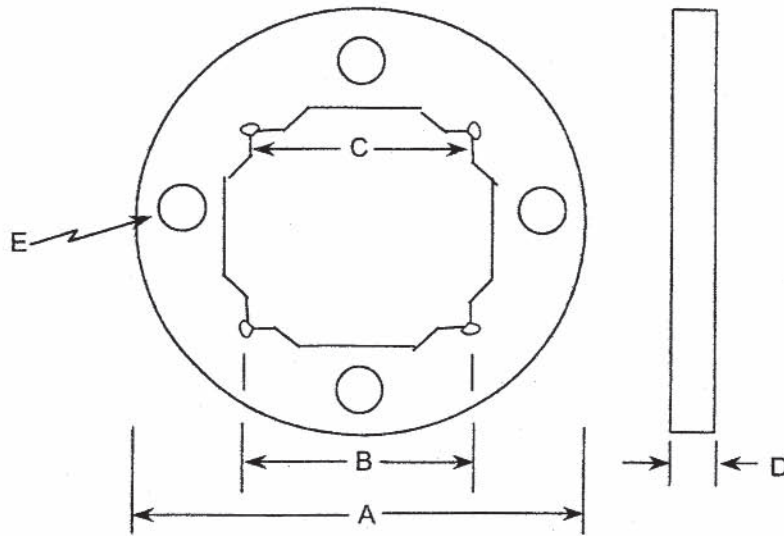

SP-PN	A.	B.	C.	D.	E.
F5001	5.00	1.875	1.75	0.188	
F5001D	5.00	1.875	1.75	.88	1/2 (4)
F7252D	7.25	3.000	2.75	.250	11/16 (4)

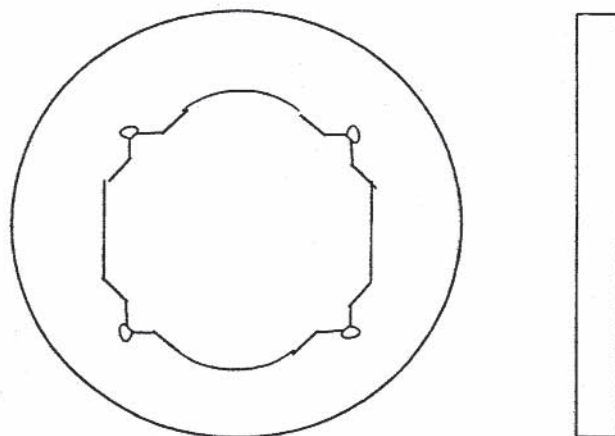

SP-PN	A.	B.	C.	D.	E.
F7254	7.25	3.00	2.75	.250	11/16 (4)

